

830-0030

ADJUSTABLE LENS MOUNTS



830-0030-02

820-0010

The 830-0030 series adjustable lens mounts provide convenient, precise optics centering and repeatable removal and replacing. Lenses are positioned and locked in place by three rigid shaft assemblies with V-groove tips. Each individually adjustable shaft incorporates a sliding sleeve for rough positioning and diameter setting and collet fix sleeve in place. A thumbscrews at the end of two orthogonal sleeves then provide fine X-Y position adjustment within 3 mm range.

Mounting holes on the support ring provide easy attachment to all mounting elements. Finish: black anodized aluminium.

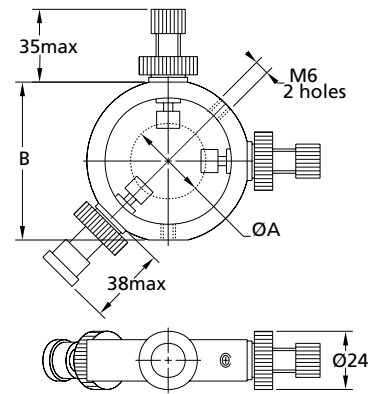

Code	Amin, mm	Amax, mm	B, mm	Weight, kg	Price, EUR
830-0030-02	20	45	65	0.21	107
830-0030-04	40	65	85	0.23	114
830-0030-06	60	85	105	0.25	121

Complementary Products

Code	Page
820-0010	8.33

830-0035

UNIVERSAL ADJUSTABLE LENS/OPTICS MOUNTS



- Holding of cylindrical objects of various diameters
- Three mounting options
- Convenient storage of tips which are not used at the moment
- Quick coarse positioning and diameter setting possibility
- Made of black anodized aluminium

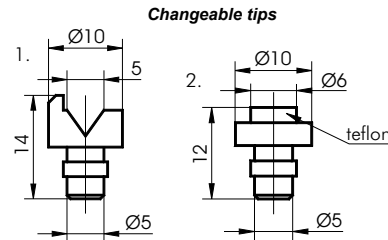
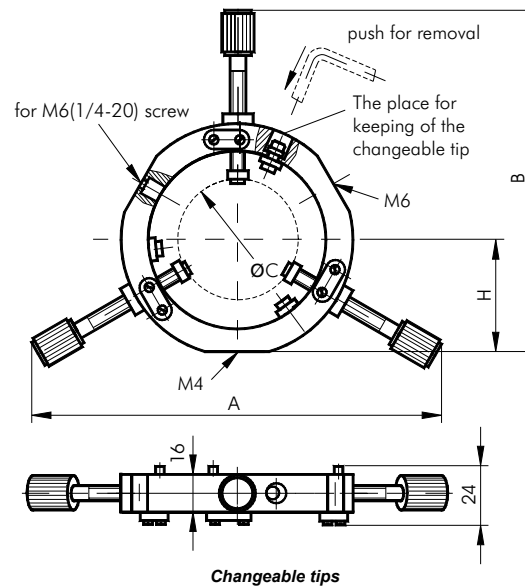

OPTICAL TABLES

BRACKETS & RAILS

BASE MOUNTS & ACCESSORIES

OPTICAL MOUNTS

OPTICAL POSITIONERS

BASE POSITIONERS

TRANSLATION & ROTATION STAGES

ADJUSTMENT SCREWS

MOTORIZED POSITIONERS